

PRESENTATION

Briquetting of biomasses

ATNA
Industrial
Solutions
GmbH

The logo for ATNA, featuring the letters 'ATNA' in a bold, dark blue, sans-serif font. The letters are set against a white circular background. A vertical line runs through the center of the circle, passing through the 'N' and extending above and below the circle's boundary.

ATNA



OUR MISSION

Revolutionising briquetting

There must be a better way! This idea drove us forward at the beginning. Previous briquetting presses were often inefficient and thus caused high costs. We had to eliminate those weak points.

Mechanical engineers, process engineers, and electrical engineers in our founding team worked together to develop an entirely new concept of briquetting technology. Today we know: We can do much better!

André Schmidt, Dipl.-Ing.
Management Board

Thomas Müller, M.Sc.
Commercial Management



START

FULL
SCREEN

PAGE 2



ATNA
Industrial
Solutions
GmbH

SCOPE OF APPLICATION



Recycling renewable resources

ATNA presses are ideal for briquetting biomass. They can process (waste) wood, bagasse, rice straw, or fermentation products.

These bio-briquettes can be used as raw materials (gasification, pyrolysis) or energy sources to fuel industrial ovens or domestic heating systems.





SCOPE OF APPLICATION

Gasification

Thanks to the excellent briquette quality, ATNA presses are ideal for preparing raw materials for use in almost all gasification methods.

For example, fine materials, such as woodchips or straw can be fed into inexpensive and efficient fixed-bed gasifiers.

Application options:

- Generating product gases such as H₂
- Fuelling combined heat and power plants (CHP)

SCOPE OF APPLICATION

Pyrolysis



Thanks to the innovative pressing process, ATNA presses are suitable for preparing input materials for pyrolysis or efficiently forming briquettes from the resulting biochar.

Application options:

- Production of biochar briquettes (barbecues, stoves)
- Generation of product gases
- Production of chunky adsorbents





SCOPE OF APPLICATION

Biofuel

Since burning briquettes made of dried biomass, such as (waste) wood, bagasse, or fermentation residues, is carbon-neutral, they are the environmentally friendly alternative to lignite briquettes.

Thanks to their high quality, briquettes can be burned on inexpensive reciprocating or travelling grates or used in domestic fireplaces.

Application options:

- Biomass briquettes for industrial combustion (as loose bulk material)
- Biomass briquettes for domestic heating purposes (as packets)

YOUR ADVANTAGES

We deliver added value

Companies that briquette biomass save on storage and transport costs and process their residual and waste materials more efficiently. Moreover, thanks to the wide range of potential applications, they can enter new business fields in the areas of pyrolysis, gasification, or combustion.



**DEVELOPMENT OF
NEW BUSINESS AREAS**



**QUICK
AMORTISATION**



**ENVIRONMENTALLY
FRIENDLY
RECYCLING**



START

OUR SOLUTION

GreenLine briquetting presses

The multi-stage pressing process of ATNA GreenLine presses allows maximum flow rates while ensuring the highest briquette quality. To this end, we deliver innovative solutions tailored to your company.

FULL
SCREEN

PAGE 8



ATNA
Industrial
Solutions
GmbH

Multi-stage pressing method

Thanks to our novel turret punch press and multi-stage pressing method, which consists of precompacting, pre-pressing, pressing, and ejection, we are able to achieve high flow rates at low energy consumption.

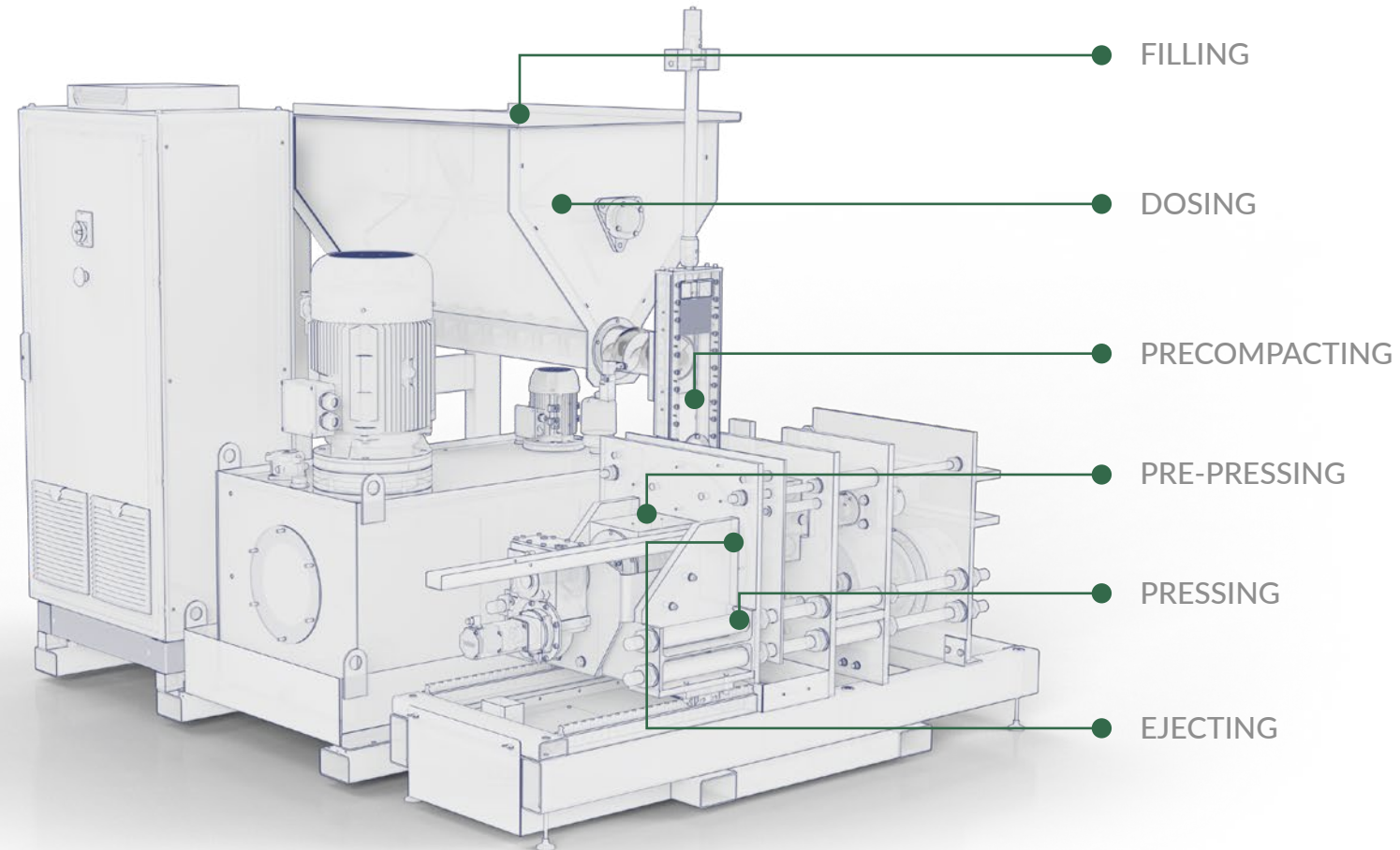

Biomass briquettes

Corncobs



Rice straw



Forest residues



Fermentation products



Fresh wood



Bagasse



START

TECHNICAL SPECIFICATIONS

GreenLine Briquetting presses

FULL
SCREEN

PAGE 11



ATNA
Industrial
Solutions
GmbH

Operating parameters

Our briquette presses can be customised to suit your requirements. Depending on the application, we can customise technical parameters such as pressing power, flow rate, and format.

START

MAXIMUM PRESSING POWER

Can be customised acc. to the material

up to
300
MPa

FLOW RATES

From 50 kilograms to 10 tonnes per hour

50 > 16,000
kg/h kg/h

FORMATS

Shape can be freely selected, from Ø 20 mm up to 100x100 mm

20 – 100
mm



FULLY AUTOMATIC CONTINUOUS

operation day and night

24 / 7
h days

FULL SCREEN

PAGE 12



ATNA
Industrial
Solutions
GmbH

TECHNICAL SPECIFICATIONS

GreenLine

Our GreenLine briquette presses fit perfectly into your production environment. Thanks to the compact external dimensions, straightforward installation without the need for additional foundation, and the simple connection, you will be able to use the press and reduce your costs right away. The technical specifications listed here refer to a standard GreenLine briquette press without additional features.

STANDARD

WEIGHT

approx. 3,900 kg
(without hydraulic oil)

CONNECTION PARAMETERS

400 V
/ 63 A

DIMEN- SIONS

Length: 2700 mm
Width: 2150 mm
Height: 2250 mm

START

FULL
SCREEN

PAGE 13



ATNA
Industrial
Solutions
GmbH

YOUR OPTIONS

Extension options

- Upstream chip shredder
- Online dashboard with mobile access
- Automatic wear measurement
- Automatic density measurement
- Adjustable hydraulic system
- Extraction system for dusty materials
- Remote maintenance to ensure timely service
- Preparation for outdoor installation



START

FULL
SCREEN

PAGE 14



ATNA
Industrial
Solutions
GmbH

YOUR WISHES

Customised solutions

Every company is unique. For this reason, we work with our customers to develop individual solutions tailored to their requirements.

We provide connection to customer's workflows, such as complete extraction systems for in-house material transport to the briquetting press.

START

FULL
SCREEN

PAGE 15



ATNA
Industrial
Solutions
GmbH

Many thanks for your attention

GET IN TOUCH WITH US!

START

ATNA INDUSTRIAL SOLUTIONS GMBH

 Zschortauer Straße 76, 04129 Leipzig

 0341 / 9188 1833

 info@atna-solutions.com

www.atna-solutions.com

FULL
SCREEN

Gefördert durch:



*Zusammen.
Zukunft.
Gestalten.* 



ATNA
Industrial
Solutions
GmbH